

PACER®

12 VOLT P-1275



- CAPACITY** 145 Ah
- MATERIAL** Polypropylene
- BATTERY** Deep-Cycle Flooded/Wet Lead-Acid Battery
- COLOR** Black
- WATERING** Required

ELECTRICAL SPECIFICATIONS

VOLTAGE	12			
CELL(s)	6			
CAPACITY^A MINUTES	98 @ 56 AMPS			
CAPACITY^B AMP-HOURS (Ah)	5	10	20	100
	116	129	145	160
ENERGY [kWh]	1.92 @ 100 Hr			

CHARGING INSTRUCTIONS

CHARGER VOLTAGE SETTINGS (AT 77°F/25°C)				
SYSTEM VOLTAGE	12V	24V	36V	48V
Bulk Charge	14.82	29.64	44.46	59.28
Float Charge	13.50	27.00	40.50	54.00
Equalize Charge	16.20	32.40	48.60	64.80

Do not install or charge batteries in a sealed or non-ventilated compartment. Constant under or overcharging will damage the battery and shorten its life as with any battery.

PHYSICAL SPECIFICATIONS

BCI	GC12		
MODEL	P-1275		
TERMINAL TYPE^C	EMBEDDED LOW PROFILE TERMINAL		
DIMENSIONS^D INCHES (mm)	LENGTH	WIDTH	HEIGHT ^E
	12.96 [329]	7.13 [181]	10.71 [272]
WEIGHT^F LBS. (kg)	81.5 [37]		
HANDLE	J- HOOK LIFTING STRAP		
INSTALLATION ORIENTATION	VERTICAL/UPRIGHT		

CHARGING TEMPERATURE COMPENSATION

ADD	SUBTRACT
0.005 volt per cell for every 1°C below 25°C 0.0028 volt per cell for every 1°F below 77°F	0.005 volt per cell for every 1°C above 25°C 0.0028 volt per cell for every 1°F above 77°F

OPERATIONAL DATA

OPERATING TEMPERATURE	SELF DISCHARGE
-4°F to 113°F [-20°C to +45°C]. At temperatures below 32°F [0°C] maintain a state of charge greater than 60%.	5 - 15% per month depending on storage temperature conditions.

STATE OF CHARGE MEASURE OF OPEN-CIRCUIT VOLTAGE

PERCENTAGE CHARGE	SPECIFIC GRAVITY	CELL	12 VOLT
100	1.277	2.122	12.73
90	1.258	2.103	12.62
80	1.238	2.083	12.50
70	1.217	2.062	12.37
60	1.195	2.040	12.24
50	1.172	2.017	12.10
40	1.148	1.993	11.96
30	1.124	1.969	11.81
20	1.098	1.943	11.66
10	1.073	1.918	11.51



BATTERY DIMENSIONS

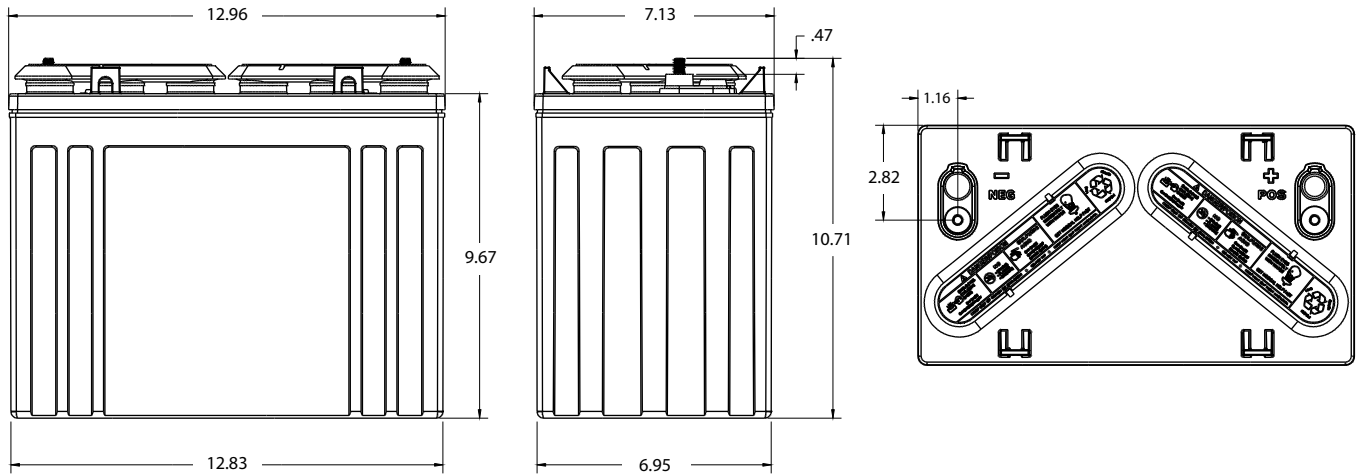

TERMINAL SPECIFICATIONS^C

TYPE	ELPT
DESCRIPTION	EMBEDDED LOW PROFILE TERMINAL
HEIGHT INCHES [mm]	1.22 [31]
TORQUE POUNDS [Nm]	95-105 [11-12]
BOLT	5/16"

PERFORMANCE

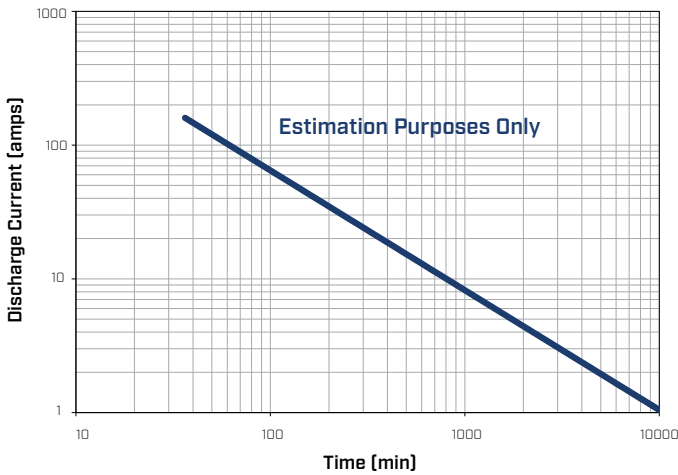

PERCENT CAPACITY VS. TEMPERATURE

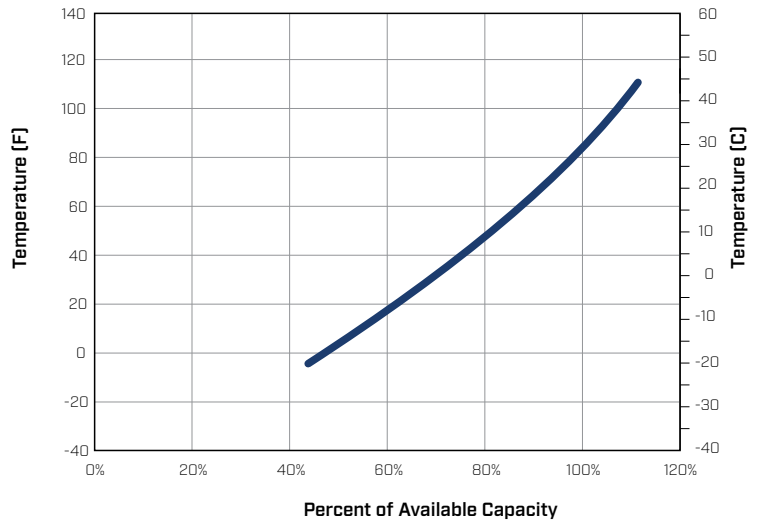

PACER BATTERY COMPANY
WITH QUALITY SYSTEM
CERTIFIED BY DNV
ISO 9001:2015

Designed in compliance with applicable BCI standards.
Tested in compliance to BCI standards.



- A. The number of minutes a battery can deliver when discharged at a constant rate at 80°F (27°C) and maintain a voltage above 1.75 V/cell. Capacities are based on peak performance.
- B. The amount of amp-hours (Ah) a battery can deliver when discharged at a constant rate at 80°F (27°C) and maintain a voltage above 1.75 V/cell. Capacities are based on peak performance.
- C. Terminal images are representative only.

- D. Dimensions may vary depending on type of handle or terminal. Batteries should be mounted with 0.5 inches (12.7 mm) spacing minimum.
- E. Height taken from bottom of the battery to the highest point on the battery. Heights may vary depending on type of terminal.
- F. Weight may vary.

P2025007-P-1275-Pacer-Datasheet

